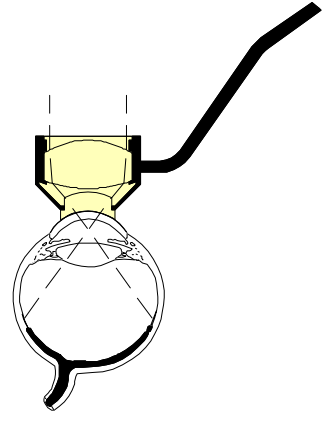

Ocular Peyman Pediatric Wide Field Vitrectomy Lens

| | Product Code | Image Mag | Diopter | Static FOV | Dynamic FOV | Lens Diameter | | |
|---|--------------|-----------|---------|------------|-------------|--------------------------------|---|---|
|  | OPPWW | .5x | 151 | 94° | 129° | 7mm Contact 13.6mm Body | Designed with: Gholam A. Peyman, M.D. New Orleans, LA |  |
| | CE | | | | | | | |

Lens Design - Wide Field

- The *Peyman Pediatric Wide Field Lens* is a two-piece lens designed for clinical situations where autoclaving is the primary method used for sterilization.
- Excellent for panoramic viewing of the far peripheral retina for both premature infants and adult patients.
- Its wide field of view and low magnification make it particularly useful during fluid-gas exchanges.
- Excellent lens for use with media opacities such as cloudy corneas, and works well through a small pupil.
- It is the lens of choice for videotaping important procedures.

Technique

- After sterilization, the lens should be assembled, by sliding the two components together on a sterile field.
- After a suitable wetting agent is placed on the cornea, the lens is placed on the cornea.
- Many surgeons do not use an inverted image contact lens until the anterior third of the vitreous has been removed and a deeper image of the vitreous cannot be obtained with normal microscope observation.
- Turn off the coaxial and oblique illumination of the microscope, since this may lead to reflections from the contact lens surfaces. Check the positions of instruments repeatedly before and during the operation, as it is very difficult to recognize the patient's crystalline lens through a contact lens.
- In order to focus the microscope, set it to its lowest magnification and then raise the microscope head away from the patient's eye. Once focus has been achieved, magnification can be adjusted to optimize viewing conditions.
- Be sure the lens is seated well on the cornea. If the assistant has a poor image and you find the image good (or vice versa), it is possible only one observation beam path of the microscope is receiving and transmitting a good image. Slightly shifting the lens will correct the problem.
- You can bring the peripheral retina into view by tilting the contact lens a little or by shifting it horizontally. Some lenses possess large depth of field. The concavity of the fundus then appears slightly flattened, especially toward the periphery. It is also possible that the anterior parts of intraocular instruments will at first appear somewhat thicker and slight bent or curved.
- Keep endo-illumination as far as possible from the retina and increase illumination at its tip. This utilizes the wide-angle effect of the Wide Field Lens to its fullest. Light intensity at the retina will be somewhat reduced due to the distance from the retina.
- Fluid/gas exchanges, fluid/silicone exchanges and gas/silicone exchanges can be easily optically monitored even in phakic eye.

WARNING

Please adhere to the following instructions for the cleaning and sterilization of Ocular Peyman Pediatric Wide Field Vitrectomy Lens. Ocular Instruments Inc. will not be responsible for damage caused by use of alternative cleaning and sterilization methods.

Cleaning

Rinse: Immediately upon removal from patient's eye, thoroughly rinse in cool or tepid water.

Wash: Disassemble the lens by lifting the asphere from the contact cone (Figure 1). Wash each half of the lens with mild soap and water so that each element is free of mucous, sebaceous deposits, or other debris.

Caution

If fluid/gas exchange has occurred, wipe lens with alcohol to remove any trace of oil present. *If lens is not promptly and properly cleaned, permanent damage may result.*

Rinse: Rinse the elements thoroughly, then dry. When placing the elements on a surface to dry, always lay the elements as shown in (Figure 2) to avoid scratching.

Then: Proceed with sterilization instructions.

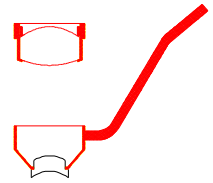

Figure 1



Figure 2

Sterilization - Autoclave

Prep: Place the two halves of the disassembled lens on their sides in sterilization case as shown in (Figure 3).

Process:

Flash autoclave (unwrapped)

| Temperature | Time |
|---------------|--------------------|
| 270°F (134°C) | 10 minutes minimum |

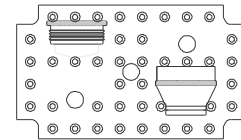

Figure 3

Caution

Use only distilled water in the steam sterilizer. If not distilled, mineral deposits from hard water (steam) will leave a cloudy film on the lens. The deposit can only be removed by regrinding and re-polishing the lens and repair costs approximate that of a new lens.

Important Note!

Moisture inside the lens may cause fogging of the lens during use. To avoid such fogging dry the internal surfaces of both halves of the lens after autoclaving and allow them to cool to room temperature prior to assembling.

Sterilization - ETO

| Minimum Time | Temperature | Aeration Time |
|--------------|--------------|---------------|
| 1 hour | 130°F (54°C) | 12 hours |

Sterilization - Steris System 1

OPPWF - Not Compatible

Sterilization - Sterrad

Follow manufacturer's instructions.

NOTE

Discoloration of the lens handle may occur using Sterrad. Optical Function will not be changed.

Sterilization for Autoclavable Lens Cleaning Cloth (OLCCA)

Flash autoclave (unwrapped) at a minimum of 270°F (134°C) for a minimum of 10 minutes.

For information on compatibility with alternative product care methods, contact Customer Service.



2255 116th Ave NE, Bellevue, Washington 98004-3039 USA
 T: 425-455-5200 or 800-888-6616 F: 425-462-6669
 E: ocular@ocular-instruments.com I: www.ocular-instruments.com

© 2003 Ocular Instruments
 7825B3017