

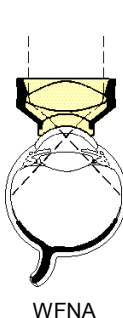
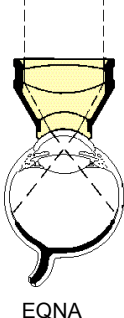

## Ocular Landers NA Wide Field & NA Equatorial Vitrectomy Lenses

	<b>Product Code</b> CE	Image Mag	Diopter	Static FOV	Dynamic FOV	Lens Height	Designed with: Maurice B. Landers, III, M.D. Chapel Hill, NC	 WFNA	 EQNA
	<b>OLIV-WFNA</b>	0.38x	155	130°	146°	11.8mm			
	<b>OLIV-EQNA</b>	0.65x	91	101°	131°	14.4mm			

### Lens Design - NA Wide Field

- The *Landers NA (non-autoclavable) Wide Field Vitrectomy Lens* is a single-piece lens designed for clinical situations where autoclaving is either not available or not required for quick turnaround.
- Excellent for panoramic viewing of the far peripheral retina and laser photocoagulation when managing a peripheral retinal tear or giant retinal tear.
- Its wide field of view and low magnification make it particularly useful during fluid-gas exchanges.
- Excellent lens for use with media opacities such as cataracts and cloudy corneas, and works well through a small pupil.
- It is the lens of choice for videotaping important procedures.

### Lens Design - NA Equatorial

- The *Landers NA (non-autoclavable) Equatorial Vitrectomy Lens* is a single-piece lens designed for clinical situations where autoclaving is either not available or not required for quick turnaround.
- It is excellent for delicate membrane peeling around the optic nerve and off of the major vascular arcades.
- It also provides an excellent image for delicate work around the macula such as macular hole surgery or peeling of epiretinal membranes from the macula.

### Technique

- The lens may be held on the eye by an assistant using the Landers Lens Handle (OLIV-H) or by suturing one of the Landers Lens Rings to the sclera.
- After a suitable wetting agent is placed on the cornea, the lens is placed on the cornea.
- Many surgeons do not use an inverted image contact lens until the anterior third of the vitreous has been removed and a deeper image of the vitreous cannot be obtained with normal microscope observation.
- Turn off the coaxial and oblique illumination of the microscope, since this may lead to reflections from the contact lens surfaces. Check the positions of instruments repeatedly before and during the operation, as it is very difficult to recognize the patient's crystalline lens through a contact lens.
- In order to focus the microscope, set it to its lowest magnification and then raise the microscope head away from the patient's eye. It is suggested that one work at the lowest magnification. Most surgeons reduce magnification after they become familiar with the IVS so they may achieve more field of view.
- Be sure the lens is seated well on the cornea. If the assistant has a poor image and you find the image good (or vice versa), it is possible only one observation beam path of the microscope is receiving and transmitting a good image. Slightly shifting the lens will correct the problem
- You can bring the pars plana into view by tilting the contact lens a little or by shifting it horizontally. Some lenses possess large depth of field. The concavity of the fundus then appears slightly flattened, especially toward the periphery. It is also possible that the anterior parts of intraocular instruments will at first appear somewhat thicker and slight bent or curved.
- Keep endo-illumination as far as possible from the retina and increase illumination at its tip. This utilizes the wide-angle effect of the Wide Field Lens to its fullest. Light intensity at the retina will be somewhat reduced due to the distance from the retina.
- Fluid/gas exchanges, fluid/silicone exchanges and gas/silicone exchanges can be easily be optically monitored even in phakic eye with the Wide Field Lens.

## Cleaning

Rinse: Immediately upon removal from patient's eye, thoroughly rinse in cool or tepid water.

Wash: Place a few drops of mild soap on a moistened cotton ball. Gently clean with a circular motion.

Rinse: Thoroughly rinse in cool or tepid water, then dry carefully with a *non-linting* tissue.

Then: Proceed with either disinfection or sterilization instructions.

## Disinfection

Soak In:	<b>GLUTARALDEHYDE</b>		<b>OR</b>	<b>BLEACH</b>		
	2% or 3.4% aqueous solution			10% solution mixed at: 1 part bleach to 9 parts cool tepid water		
	Temperature per manufacturer instructions			Recommended exposure time = 10 minutes		
	Minimum exposure time = 20 minutes					
<b>CAUTION</b>		<i>To avoid damage to the lens, do not exceed recommended exposure time.</i>				
Then:	Rinse lens <i>thoroughly</i> to remove disinfection solution. 3 cycles of 1 minute, with cool or tepid water is recommended. Dry carefully and place in a dry storage case.					
NOTE	This lens is known to be compatible with: Asepti-Wipe, Cavi-cide, Cidex, Cidex OPA, DisCide Wipe, Enviro-cide, H <sub>2</sub> O <sub>2</sub> -3%, and Opti-Cide.					

## Sterilization

AUTOCLAVE	STERRAD	STERIS SYSTEM 1	ETO	ETO Parameters		
NO	NO	YES	YES	Minimum Time	Temperature	Aeration Time
		Per manufacturer instructions	See Right	1 hour	130°F (54°C)	12 hours
<b>WARNING</b>		<b><i>Never Steam Autoclave or Boil this lens. Never soak in Alcohol, Acetone or other solvents.</i></b>				

### Sterilization for Autoclavable Lens Cleaning Cloth (OLCCA)

Flash autoclave (unwrapped) at a minimum of 270°F (134°C) for a minimum of 10 minutes.

For information on compatibility with alternative product care methods, contact Customer Service.

